



DATE 21 April, 2014

No. V-70002

Messrs. Non Invasive Blood Pressure Monitors

SPECIFICATION

AP3xx-044KG-NIBP
AG3xx-044KG-NIBP
AP3xx-050KG-NIBP
Model: AG3xx-050KG-NIBP

Project: _____

Distributor: _____

Reference: _____

Fujikura Ltd.

Table of Contents

- 1. General 2
- 2. Principle 2
- 3. Device lineup 2
- 4. RoHS..... 2
- 5. Block Diagram and Pin Connections 3
- 6. Device Name Code..... 4
- 7. Absolute Maximum Rating 5
- 8. General Specifications 5
- 9. Electrical Characteristics..... 6
- 10. Output versus Input Pressure 8
- 11. Transfer Function..... 9
- 12. Single Point Pressure Threshold Detection 10
- 13. Operating Sequence 11
- 14. Device Marking 12
- 15. Soldering 13
- 16. Dimensions and Weights 13
- 17. Ordering Information..... 14
- 18. Tape & Reel Information 14
- 19. Footprint for PCB (for Reference)..... 15
- 20. Notes..... 16
- Appendix: Dimension Drawing..... 17
 - 9-772-001 APxxN..... 17
 - 9-772-002 APxxR 18
 - 9-772-003 AGxx3..... 19
 - 9-772-004 AGxx6..... 20

Table shown below is revision records of this specification

Rev.	Est.	Date	Name	Comment	Mark
		21 April, 2014	Y.Uchiumi		

1. General

This document describes the specifications of Fujikura Pressure Sensors, Type of AP3xx-044KG-NIBP, AG3xx-044KG-NIBP, AP3xx-050KG-NIBP and AG3xx-050KG-NIBP. This product is modified for Non-Invasive Blood Pressure Monitors.

2. Principle

Fujikura Pressure Sensor is composed of a silicon piezoresistive pressure sensing chip and a signal conditioning integrated circuit. The low-level signal from the sensing chip is amplified, temperature compensated, calibrated, and finally converted to a high-level output signal that is proportional to the applied pressure.

3. Device lineup

This device has the following lineup.

Model	Pressure Type	Supply Voltage	Accuracy	Pressure Range (kPa)		
				0	43.996 kPa (330 mmHg)	49.996 kPa (375 mmHg)
AP3 or AG3	Gauge	5.0 Vdc or 3.3 Vdc	±2.5 mmHg			

Features

- Low Noise
- Single Point Pressure Threshold Detection

4. RoHS

This device is compliant with the Restriction of the use of certain Hazardous Substances in Electrical and Electronic Equipment (RoHS).

5. Block Diagram and Pin Connections

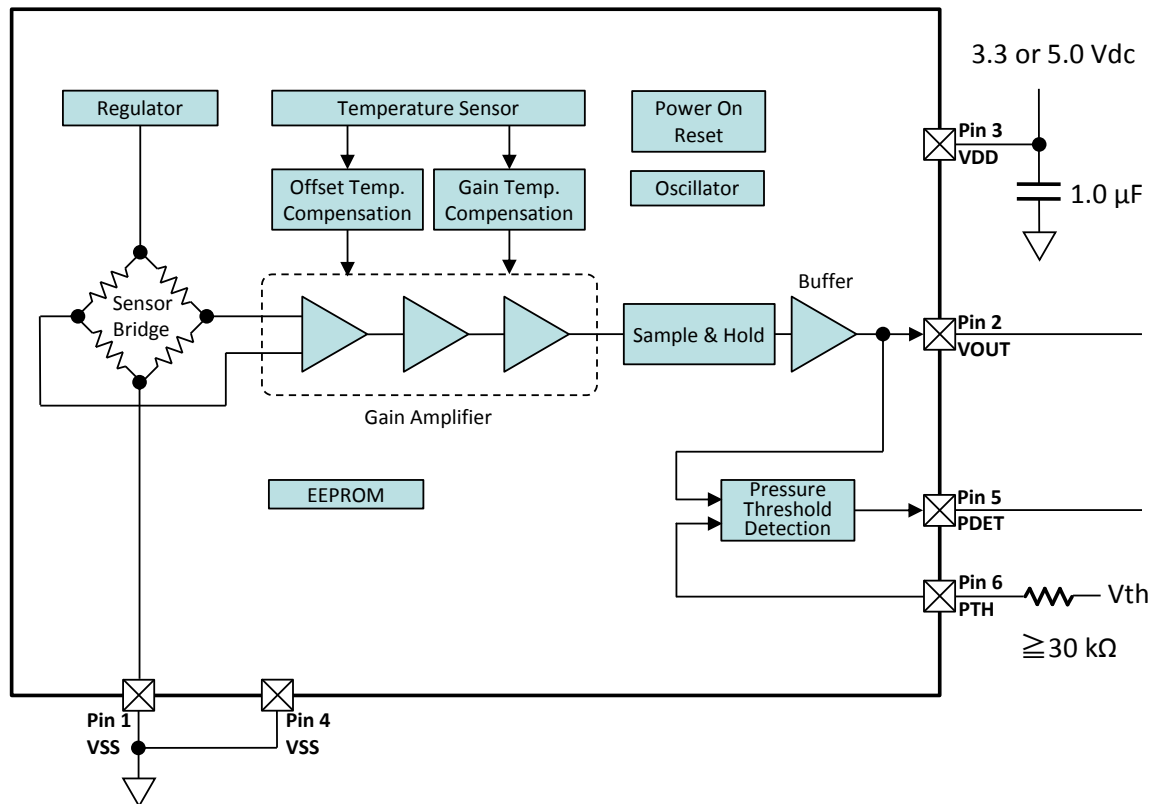

Pin Assignment		Pin No.	Pin Name	I/O	Type	Function	
AP3	AG3						
		1	VSS	-	-	Common voltage connection	*1
		2	VOUT	O	Analog	Analog output	
		3	VDD	-	-	Power supply connection	*2
		4	VSS	-	-	Common voltage connection	*1
		5	PDET	O	Digital	Pressure threshold detection	
		6	PTH	I	Analog	Pressure threshold input	*3, 4

Notes:

- *1) Both Pin 1 and Pin 4 must be connected to VSS.
- *2) Put a 1.0 μ F capacitor between Pin3 (VDD) and VSS.
- *3) Put a resistor in series with Pin6 (PTH), when inputting threshold voltage (V_{th}). The minimum resistance value is 30 k Ω .
- *4) If an application does not use Pressure Threshold Detection, put a pull-up resistor between Pin6 (PTH) and VDD, or put a pull-down resistor between Pin6 (PTH) and VSS. The minimum resistance value is 30 k Ω .

6. Device Name Code

The Device name code is consisted of Sensor code, Pressure code, Custom ID and Packing style. For the exact ordering device number, please refer to Chapter 17 Ordering Information.

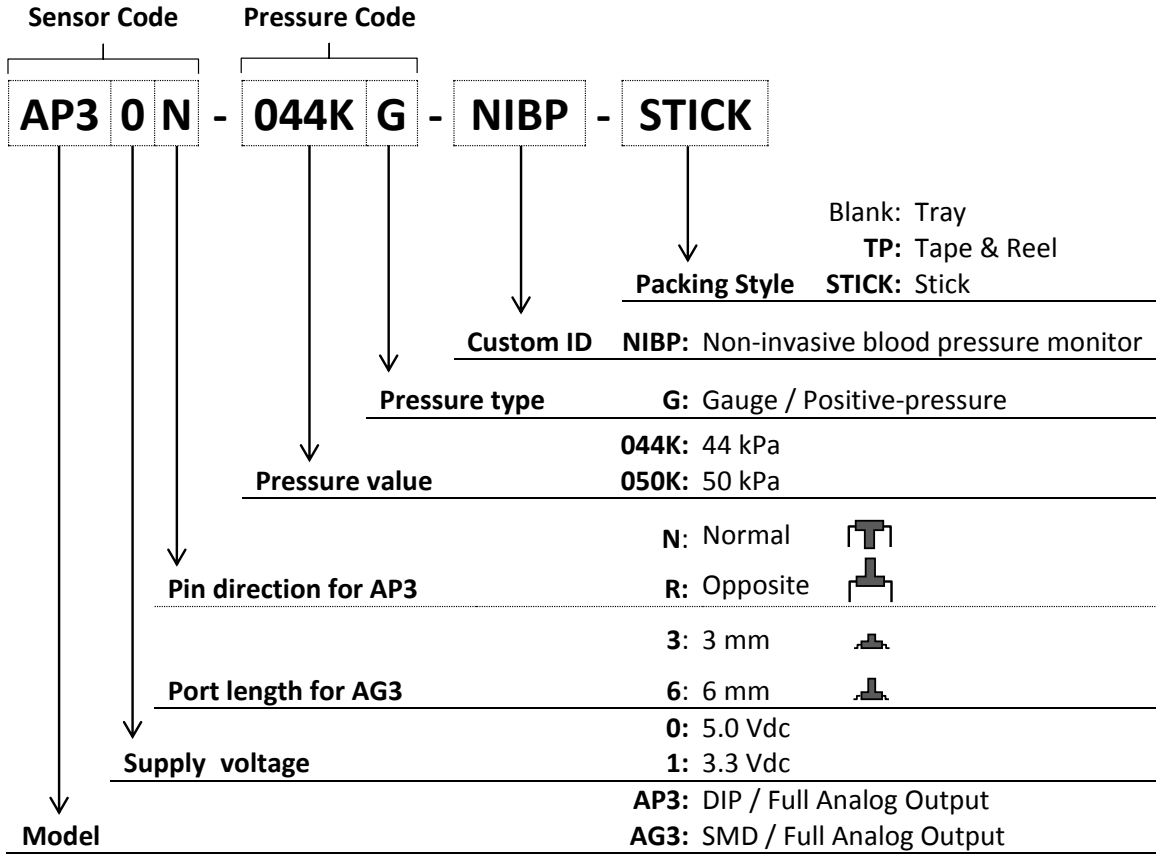

V-70002

7. Absolute Maximum Rating

Item	Symbol	Rating	Unit
Load Pressure	Pmax+	+99.992	kPa
		+750	mmHg
Supply Voltage	VDDmax	6	Vdc
Operating Temperature	Topt	-40 ~ +105	deg. C
Storage Temperature	Tstg	-40 ~ +105	deg. C

Note:

*1) Absolute maximum ratings are the limits that the device will withstand without damage.

8. General Specifications

item	Condition		Symbol	Rating			Unit	
				Min.	Typ.	Max.		
Supply Voltage	Sensor Code	AP30x, AG30x	VDD	4.75	5	5.25	Vdc	*1
		AP31x, AG31x		3.135	3.3	3.465		
Type of Pressure			-	Gauge pressure				*2
Pressure Range	Pressure Code	044KG	Popt	0	-	+43.996	kPa	*3
				0	-	+330	mmHg	
		050KG		0	-	+49.996	kPa	
				0	-	+375	mmHg	
Pressure Media			-	Non-corrosive gases				*4
Compensated Temperature			-	0	-	+60	deg. C	*5
Operating Humidity	Non-condensing		Hopt	30	-	85	%RH	*6
Storage Humidity	Non-condensing		Hstg	30	-	85	%RH	*6
Dielectric Strength			-	-	-	1	mA	*7
Insulation Resistance			-	100	-	-	MΩ	*8

Notes:

- *1) Output voltage (Vout) is not perfectly ratio-metric with the power supply voltage (VDD).
- *2) Gauge pressure is defined as the difference between the pressure applied and atmospheric pressure.
- *3) 1 mmHg equals 0.133322 kPa. Pressure range (Popt) is defined as the measurable pressure range of the device.
- *4) Ensure the pressure media contains no particulates. The device is not compatible with liquids.
- *5) Please also refer to Chapter 11 Transfer Function.
- *6) Do not wet the device with dew.
- *7) Dielectric strength is defined as the leakage current between all pins and the package with AC500, 1 minute.
- *8) Insulation resistance is defined as the resistance value between all pins and the package with DC500V.

V-70002

9. Electrical Characteristics

Load Resistor $R_L = \infty$, Ambient temperature $T_a = 25 \text{ deg. C}$

Item	Condition	Symbol	Rating			Unit	
			Min.	Typ.	Max.		
Sensor Code: AP30x, AG30x (VDD = 5Vdc)							
Offset Voltage	Min. Popt	Voff	0.1	0.2	0.3	V	*1, 2
Full Scale Voltage	Max. Popt	Vfs	4.6	4.7	4.8	V	*3
Span Voltage	Min. to Max. Popt	SV	4.47	4.5	4.53	V	*4
Supply Current		Ic	-	-	6	mAdc	*5
Sensor Code: AP31x, AG31x (VDD = 3.3Vdc)							
Offset Voltage	Min. Popt	Voff	0.2	0.3	0.4	V	*1, 2
Full Scale Voltage	Max. Popt	Vfs	2.9	3.0	3.1	V	*3
Span Voltage	Min. to Max. Popt	SV	2.67	2.7	2.73	V	*4
Supply Current		Ic	-	-	5	mAdc	*5
Accuracy	0 to 60 deg. C, Min. Popt to 300mmHg	Error1	-2.5	-	+2.5	mmHg	*6, 7
	0 to 60 deg. C, >300mmHg	Error2	-5.0	-	+5.0	mmHg	
Temperature Offset Error	0 to 60 deg. C	TSO	-0.03	-	+0.03	V	*8
Response Time	for reference	tr	-	1	-	msec.	*9
Noise Floor	Min. Popt, with LPF & HPF	NF	-	-	0.033	mmHg p-p	*10, 11
Load Resistor	VOUT - VSS or VDD - VOUT	RL	9.5	-	-	k Ω	*5
Load Capacitance	VOUT - VSS	CL	-	-	50	pF	*12
Sampling Frequency		fs	-	8.33	-	kHz	*13

Notes:

- *1) Offset voltage (Voff) is defined as the output voltage at minimum Popt.
- *2) Offset error is calibration error of offset voltage in production. It does not include Long term offset drift. It would be suggested that application has Auto-zeroing function.
- *3) Full scale voltage (Vfs) is defined as the output voltage at maximum Popt.
- *4) Output span voltage (SV) is defined as the voltage difference between Offset voltage (Voff) and Full scale voltage (Vfs).
- *5) Supply Current (Ic) is increased depending on the value of Load resistor (RL).
- *6) Accuracy consists of the following:
 Non-linearity
 Pressure hysteresis
 Sensitivity calibration error
 Temperature errors of sensitivity over the temperature range 0 to 60 deg. C
Exclude offset error and temperature errors of offset voltage over the temperature range 0 to 60 deg. C.
- *7) Output voltage per 1 mmHg is as below:

$$\frac{SV}{\text{Max. Popt}} \text{ (mV/mmHg)}$$

Pressure Code	044KG	050KG
Sensor Code		
AP30x, AG30x	4500(mV) / 330(mmHg) = 13.636(mV/mmHg)	4500(mV) / 375(mmHg) = 12(mV/mmHg)
AP31x, AG31x	2700(mV) / 330(mmHg) = 8.181(mV/mmHg)	2700(mV) / 375(mmHg) = 7.2(mV/mmHg)

- *8) Temperature offset error (TSO) is defined as the output voltage drift by temperature.
- *9) Response time (t_r) is defined as the time for the change in output voltage from 10% to 90% or from 90% to 10% of its final value when the input pressure makes a step change.

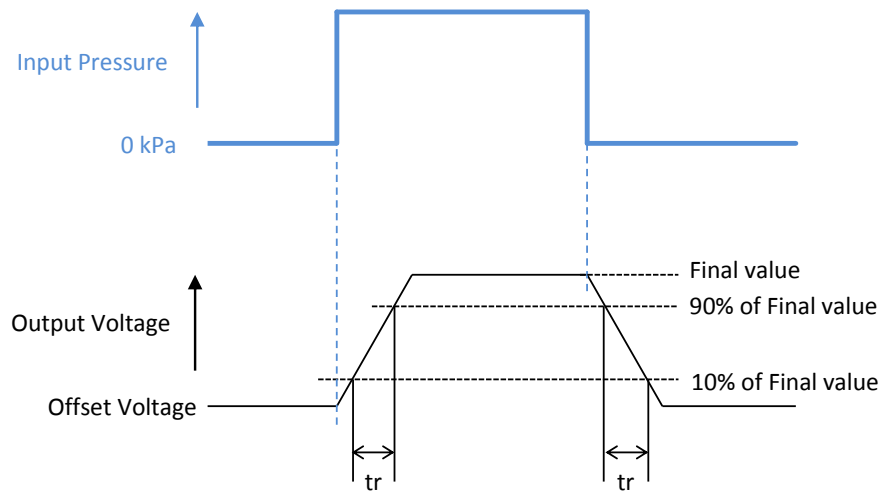

- *10) Noise floor (NF) is defined as the output voltage at 0mmHg that is filtered by HPF and LPF. This test is not processed in production.

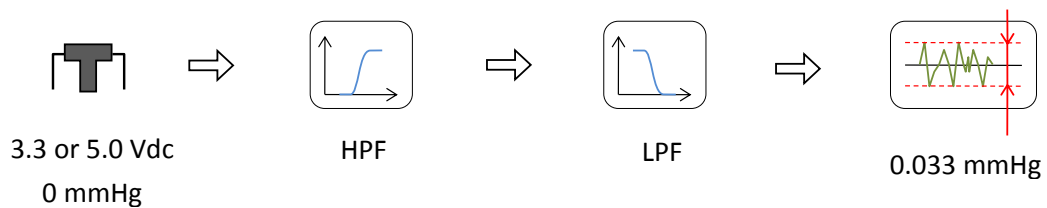

Test sequence of Noise Floor

- *11) Noise floor (NF) is increased depending on input pressure.
- *12) Do not put Load capacitance (CL) that is over 50pF between VOUT and VSS.
- *13) Output voltage (Vout) is sampled and held by the internal sampling / hold block. Sampling frequency (f_s) is 8.33 kHz. The output voltage is changed stepwise every approximately 120 microseconds.

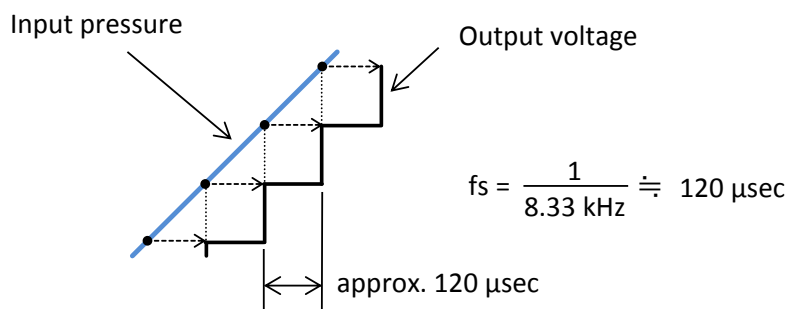

10. Output versus Input Pressure

Sensor Code	Pressure Code	
	044KG	050KG
AP30x AG30x	<p>VDD = 5.0 Vdc Temp. = 0 to 60 °C</p> <p>Output vs. Input Pressure graph for 044KG. Vfs: 4.7 V, Voff: 0.2 V. Error1: ±2.5 mmHg, Error2: ±5.0 mmHg. SV: 4.5 V. Min. Popt: 0 mmHg, Max. Popt: 330 mmHg.</p>	<p>VDD = 5.0 Vdc Temp. = 0 to 60 °C</p> <p>Output vs. Input Pressure graph for 050KG. Vfs: 4.7 V, Voff: 0.2 V. Error1: ±2.5 mmHg, Error2: ±5.0 mmHg. SV: 4.5 V. Min. Popt: 0 mmHg, Max. Popt: 375 mmHg.</p>
	AP31x AG31x	<p>VDD = 3.3 Vdc Temp. = 0 to 60 °C</p> <p>Output vs. Input Pressure graph for 044KG. Vfs: 3.0 V, Voff: 0.3 V. Error1: ±2.5 mmHg, Error2: ±5.0 mmHg. SV: 2.7 V. Min. Popt: 0 mmHg, Max. Popt: 330 mmHg.</p>

11. Transfer Function

$$V_{out} = VDD \times ((P \times \alpha) + \beta) \pm (\text{Pressure Error} \times \text{Temperature Error Multiplier} \times \alpha \times VDD)$$

Parameters:

Sensor Code	Parameter Pressure Code	VDD (*1)	P	α	β	Pressure Error
AP30x	044KG	5.0±0.25 V	0 ~ +330 mmHg	3/1100	1/25	2.5 mmHg
AG30x	050KG		0 ~ +375 mmHg	3/1250		
AP31x	044KG	3.3±0.165 V	0 ~ +330 mmHg	3/1210	1/11	
AG31x	050KG		0 ~ +375 mmHg	3/1375		

Note:

*1) Output voltage (Vout) is not perfectly ratio-metric with the power supply voltage (VDD).

Temperature Error Multiplier

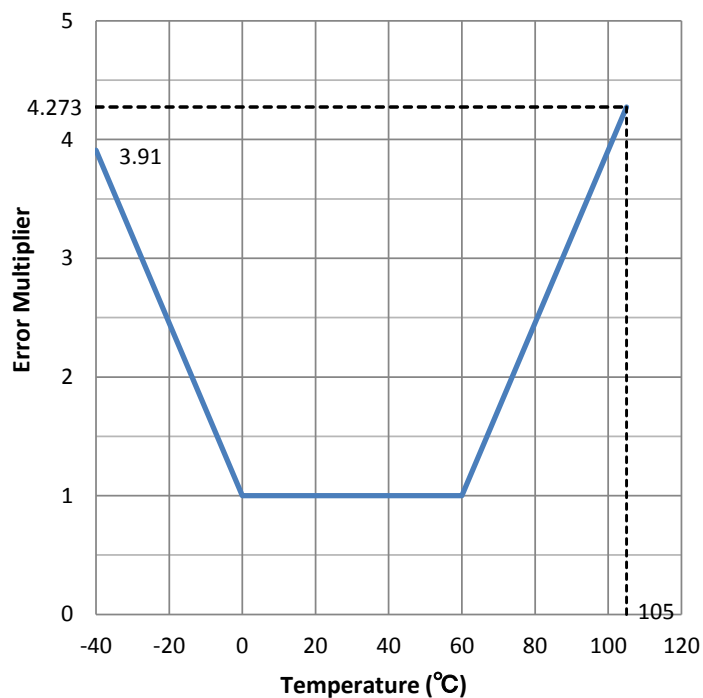

12. Single Point Pressure Threshold Detection

AP3 and AG3 have a voltage detector. Output voltage (VOUT) and threshold voltage from PTH are inputted into the detector. Detector's output will be changed when VOUT reaches a threshold voltage.

Ambient temperature Ta=25 deg. C

Item	Condition	Symbol	Rating			Unit
			Min.	Typ.	Max.	
Type of Output		PDET	CMOS output			*2
Threshold Input voltage	PTH	Vth	0.1*VDD	-	0.9*VDD	V
Input Impedance	PTH	Zin	1	-	-	MΩ
Output voltage	VOUT < Vth	V _{OH}	0.9*VDD	-	-	V
	VOUT ≥ Vth	V _{OL}	-	-	0.1*VDD	V
Pressure Hysteresis		Phys	-	0.05*VDD	-	V
Detection Time		Tdetr	-	150	-	μsec
Non Detection Time		Tdetf	-	150	-	μsec

Notes:

- *1) Do not control any device directly using this function. Because there is indeterminate status during the supply voltage rises.
- *2) Equivalent circuits of PDET and PTH are as below:

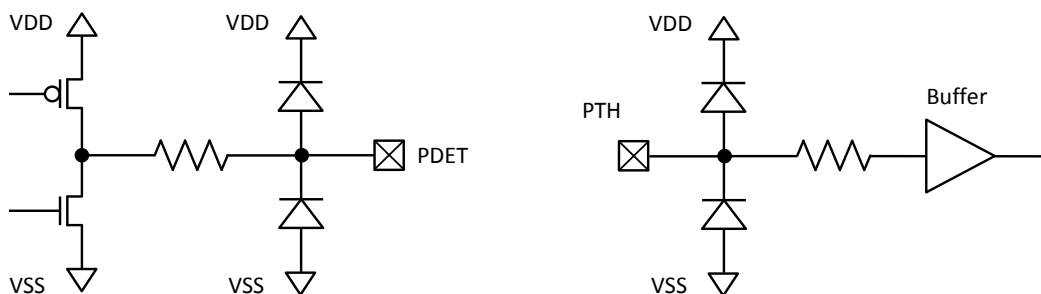

- *3) Please also refer to the following timing chart.

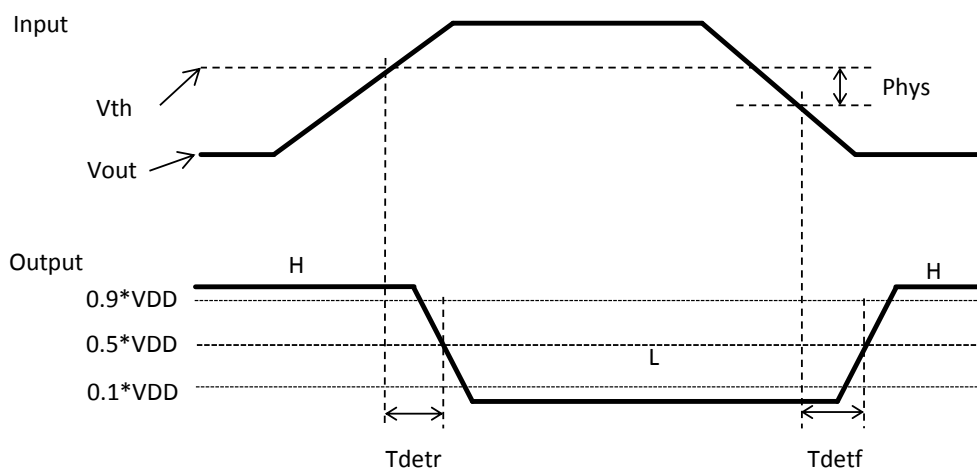

13. Operating Sequence

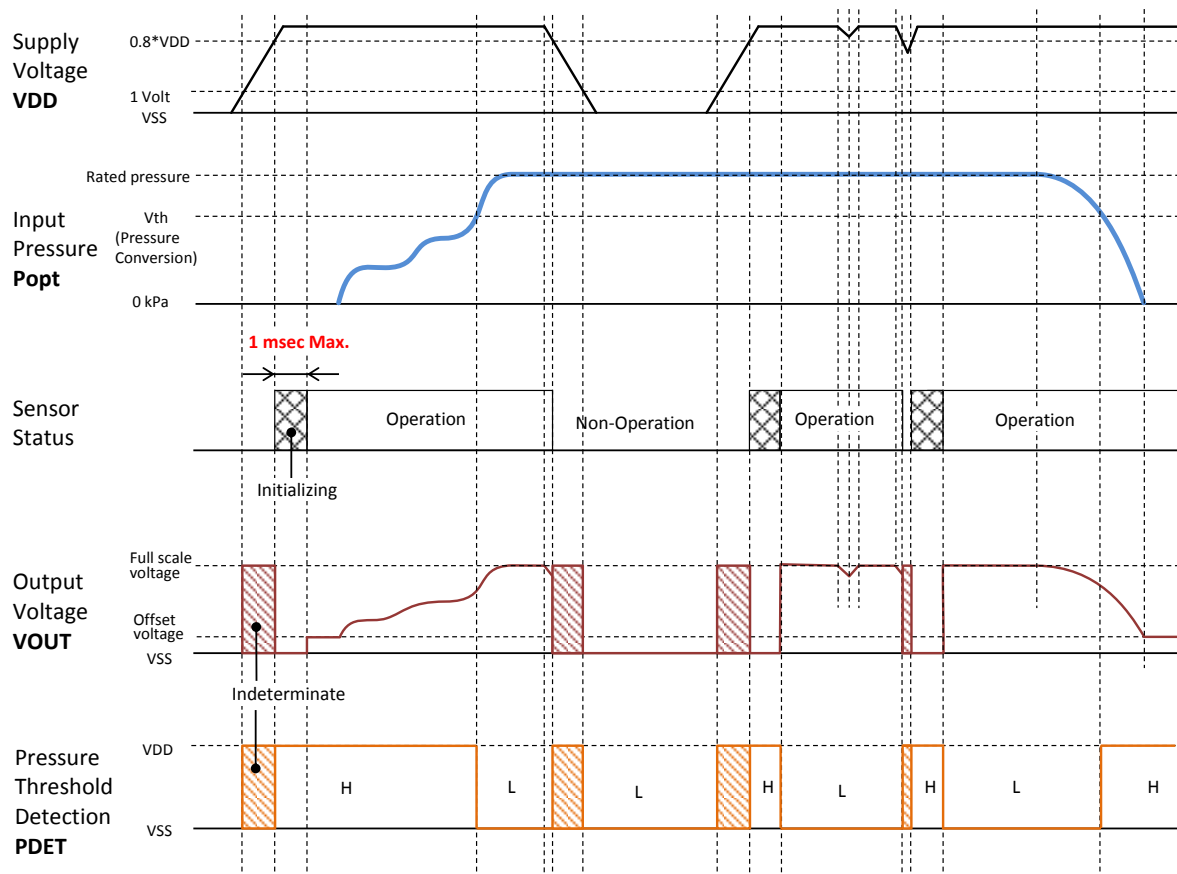

Notes:

- *1) Before supply voltage reaches $0.8 \cdot VDD$, the status of VOUT, PDET and PTH are indeterminate.
- *2) After reaching $0.8 \cdot VDD$, initializing process is started. At initializing process, PDET is fixed $0.9 \cdot VDD$ and over, and VOUT is fixed $0.1 \cdot VDD$ and under.

14. Device Marking

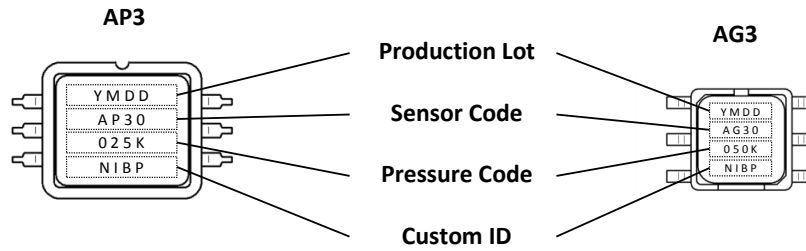

Items		Marking
Production Lot		
Y	Last digit of Production year	0~9
M	Production month	1, 2, 3 ~ 8, 9, X=Oct., Y=Nov., Z=Dec.
DD	Production date	01~31
Sensor Code		
	AP30x	AP30
	AP31x	AP31
	AG30x	AG30
	AG31x	AG31
Pressure Code		
	044KG	044K
	050KG	050K
Custom ID		NIBP

*1

Note:

*1) Pin direction of AP3 and Port length of AG3 is not marked on the face plate.

15. Soldering

Process	Sensor Code	Condition																		
Hand soldering	AP3xx	Soldering iron temperature: 350 deg. C max. Soldering time: 3 seconds max. / each pin																		
Wave soldering	AP3xR	Soldering bath temperature: 260 deg. C max. Soldering time: 5 seconds max.																		
Reflow soldering	AG3xx	<p style="text-align: center;">Soldering Profile</p> <table border="1" style="margin-top: 10px;"> <thead> <tr> <th></th> <th></th> <th></th> </tr> </thead> <tbody> <tr> <td>A</td> <td>Ramp up</td> <td>2 to 4 deg. C / sec.</td> </tr> <tr> <td>B</td> <td>Pre-heating</td> <td>150 to 180 deg. C 60 to 120 sec.</td> </tr> <tr> <td>C</td> <td>Ramp up</td> <td>2 to 4 deg. C / sec.</td> </tr> <tr> <td>D</td> <td>Heating</td> <td>Above 230 deg. C, 45 sec. max. 245 deg. C max., 10 sec. max.</td> </tr> <tr> <td>E</td> <td>Ramp down</td> <td>2 to 4 deg. C / sec.</td> </tr> </tbody> </table>				A	Ramp up	2 to 4 deg. C / sec.	B	Pre-heating	150 to 180 deg. C 60 to 120 sec.	C	Ramp up	2 to 4 deg. C / sec.	D	Heating	Above 230 deg. C, 45 sec. max. 245 deg. C max., 10 sec. max.	E	Ramp down	2 to 4 deg. C / sec.
A	Ramp up	2 to 4 deg. C / sec.																		
B	Pre-heating	150 to 180 deg. C 60 to 120 sec.																		
C	Ramp up	2 to 4 deg. C / sec.																		
D	Heating	Above 230 deg. C, 45 sec. max. 245 deg. C max., 10 sec. max.																		
E	Ramp down	2 to 4 deg. C / sec.																		

*1, 2
*1, 2
*1, 2,
3, 4

Notes:

- *1) NEVER wash the device with any washing liquid. NEVER wash the device with any ultrasonic washing machine.
- *2) Do not put the solder and flux on the device's package.
- *3) Temperature means Surface temperature of the device's package.
- *4) Reflow soldering is within two times.

16. Dimensions and Weights

Refer to the following drawing as attached.

Sensor Code	Dimension Drawing	Weights
AP3xN	9-772-001	approx. 1.4 grams
AP3xR	9-772-002	
AG3x3	9-772-003	approx. 0.3 grams
AG3x6	9-772-004	approx. 0.4 grams

17. Ordering Information

Model	Package	Pressure Range	Supply voltage	Pin direction	Packing	Ordering Device Number	Qty./Packing	
AP3	DIP	330 mmHg	5.0 Vdc	Normal	Tray	AP30N-044KG-NIBP	150 Pcs/Tray	
					Stick	AP30N-044KG-NIBP-STICK	40 Pcs/Stick	
				Opposite	Tray	AP30R-044KG-NIBP	150 Pcs/Tray	
			Sticks		AP30R-044KG-NIBP-STICK	40 Pcs/Stick		
			3.3 Vdc	Normal	Tray	AP31N-044KG-NIBP	150 Pcs/Tray	
					Stick	AP31N-044KG-NIBP-STICK	40 Pcs/Stick	
		Opposite		Tray	AP31R-044KG-NIBP	150 Pcs/Tray		
			Stick	AP31R-044KG-NIBP-STICK	40 Pcs/Stick			
		375 mmHg	5.0 Vdc	Normal	Tray	AP30N-050KG-NIBP	150 Pcs/Tray	
					Stick	AP30N-050KG-NIBP-STICK	40 Pcs/Stick	
				Opposite	Tray	AP30R-050KG-NIBP	150 Pcs/Tray	
			Stick		AP30R-050KG-NIBP-STICK	40 Pcs/Stick		
			3.3 Vdc	Normal	Tray	AP31N-050KG-NIBP	150 Pcs/Tray	
					Stick	AP31N-050KG-NIBP-STICK	40 Pcs/Stick	
		Opposite		Tray	AP31R-050KG-NIBP	150 Pcs/Tray		
			Stick	AP31R-050KG-NIBP-STICK	40 Pcs/Stick			
				Port Length				
AG3	SMD	330 mmHg	5.0 Vdc	3mm	Tray	AG303-044KG-NIBP	300 Pcs/Tray	
					Tape & Reel	AG303-044KG-NIBP-TP	500 Pcs/Reel	
				6mm	Tray	AG306-044KG-NIBP	300 Pcs/Tray	
					Tape & Reel	AG306-044KG-NIBP-TP	500 Pcs/Reel	
				3.3 Vdc	3mm	Tray	AG313-044KG-NIBP	300 Pcs/Tray
						Tape & Reel	AG313-044KG-NIBP-TP	500 Pcs/Reel
			6mm	Tray	AG316-044KG-NIBP	300 Pcs/Tray		
				Tape & Reel	AG316-044KG-NIBP-TP	500 Pcs/Reel		
			375 mmHg	5.0 Vdc	3mm	Tray	AG303-050KG-NIBP	300 Pcs/Tray
						Tape & Reel	AG303-050KG-NIBP-TP	500 Pcs/Reel
					6mm	Tray	AG306-050KG-NIBP	300 Pcs/Tray
				Tape & Reel		AG306-050KG-NIBP -TP	500 Pcs/Reel	
		3.3 Vdc		3mm	Tray	AG313-050KG-NIBP	300 Pcs/Tray	
					Tape & Reel	AG313-050KG-NIBP -TP	500 Pcs/Reel	
			6mm	Tray	AG316-050KG-NIBP	300 Pcs/Tray		
		Tape & Reel		AG316-050KG-NIBP -TP	500 Pcs/Reel			

18. Tape & Reel Information

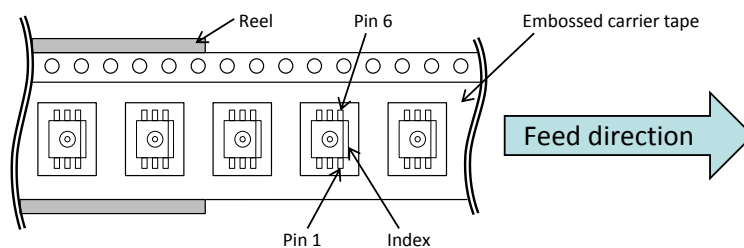

19. Footprint for PCB (for Reference)

Sensor Code	Footprint
AP3xN	
AP3xR	
AG3x3	
AG3x6	

Notes:

- *1) These footprints are for reference. Please evaluate well these footprints, before your mass production.
- *2) When designing your PCB, please also refer to the outline diagrams.

V-70002

20. Notes

- Fujikura reserves all rights.
- This document has a possibility to be changed without notice.
- Limitation, usage, environment, standard warranty and so on are listed on Fujikura web site.
- Please refer to the latest specifications.

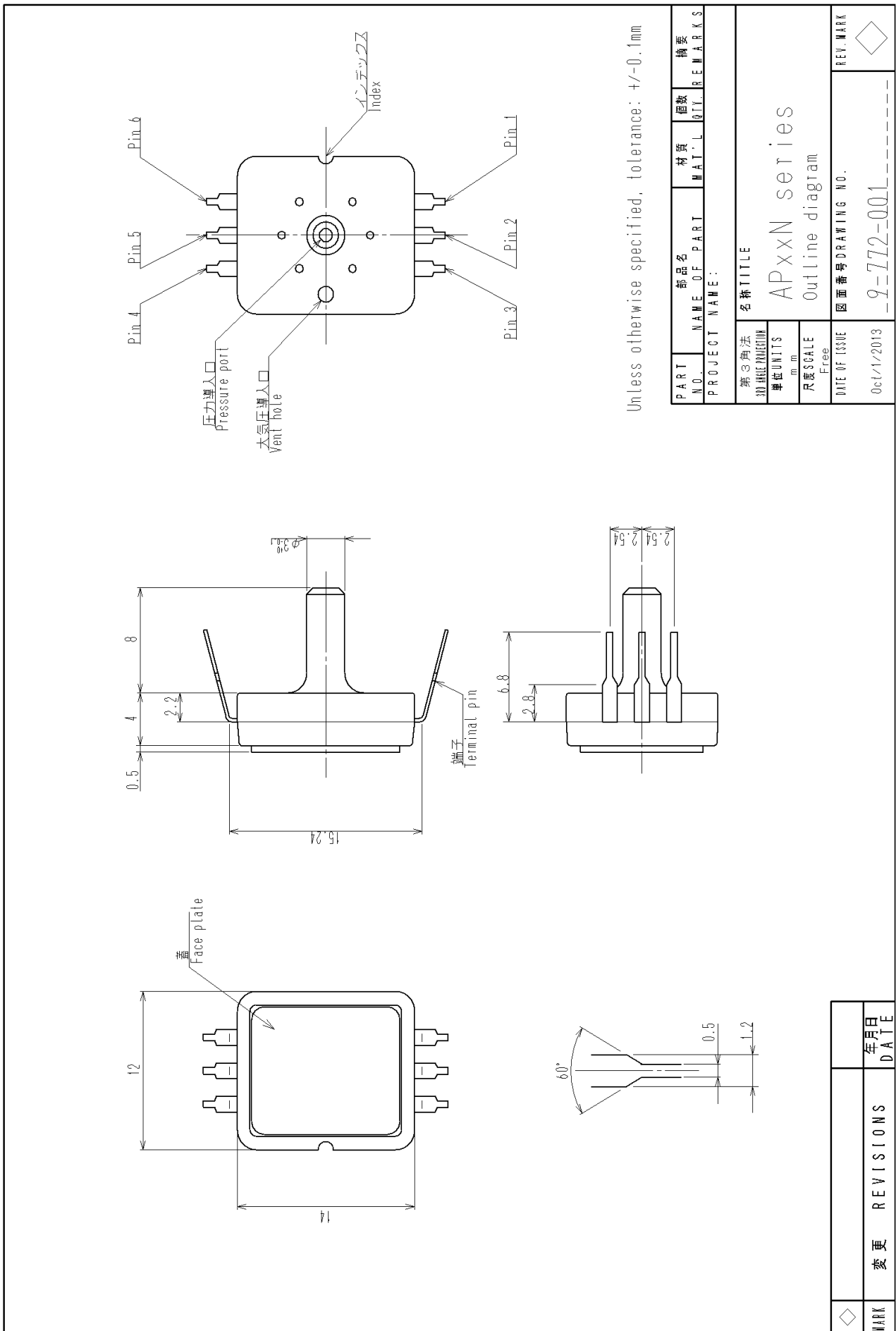

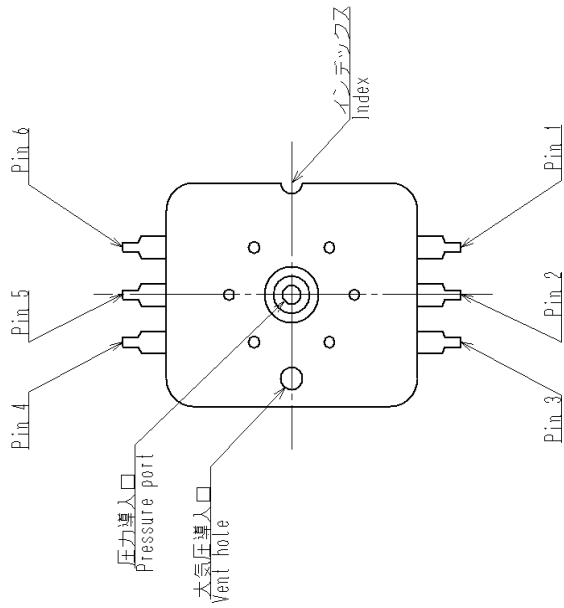

Unless otherwise specified, tolerance: $\pm 0.1\text{mm}$

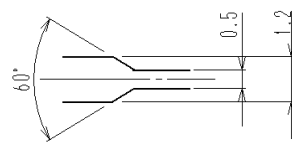
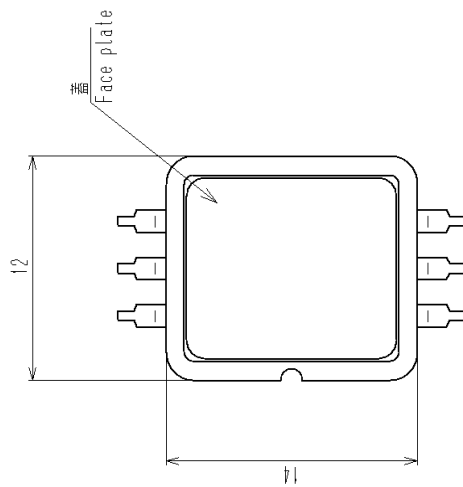
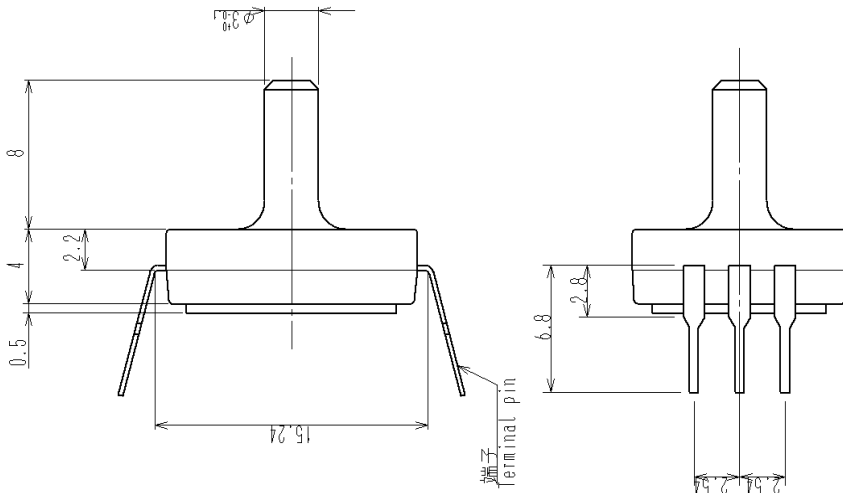

PART NO.	部品名	材質	個数	概要
PROJECT NAME :				
名称TITLE				
APxxR series				
Outline diagram				
第3角法 3D DIMENSION	單位UNITS m.m	尺碼SCALE Free	圖面番號DRAWING NO.	REV. MARK
			9-772-002	◇
DATE OF ISSUE				
Oct/1/2013				

MARK	変更 REVISIONS	年月 DATE
◇		

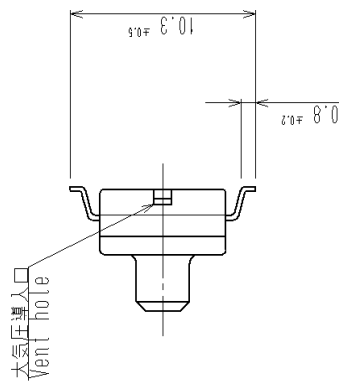
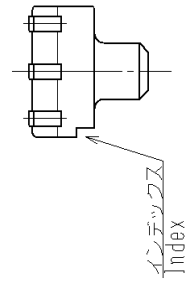
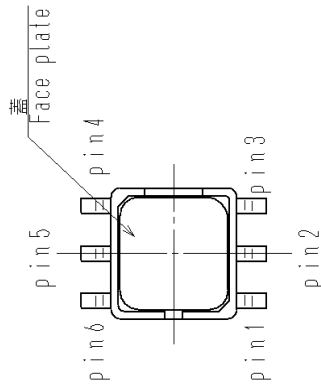
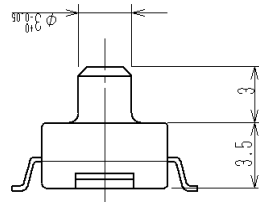
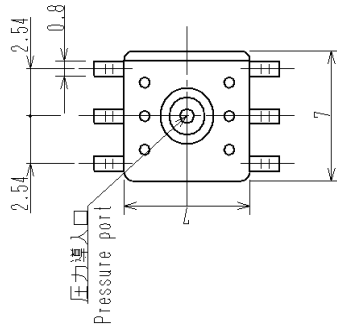

Unless otherwise specified, tolerance: $\pm 0.1\text{mm}$

PART NO.	部品名	材質	個数	備考
PROJECT NAME:				
名称TITLE				
AGxx3 series				
Outline diagram				
第3角法 3rd ANGLE PROJECTION				
単位UNITS mm				
尺度SCALE Free				
DATE OF ISSUE	図面番号DRAWING NO.			REV. MARK
0ct/1/2013	9-772-003			◇

◇	変更	REVISIONS	年月日 DATE
---	----	-----------	-------------

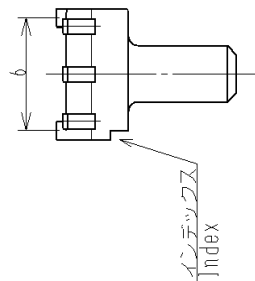
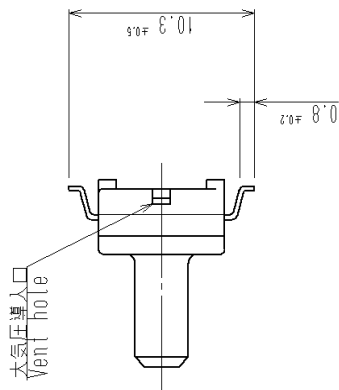
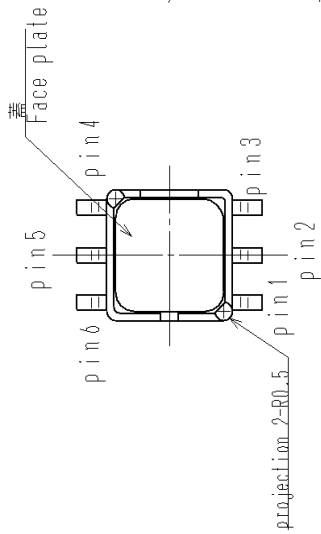
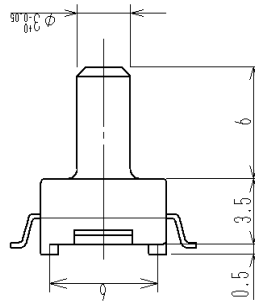
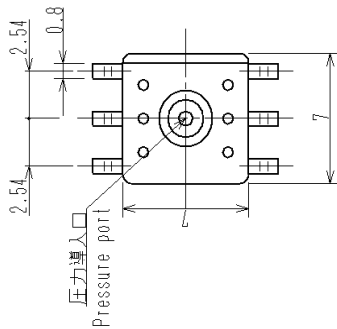

Unless otherwise specified, tolerance: $\pm 0.1\text{mm}$

PART NO.	部品名	材質	個数	摘要
NAME OF PART	MAT'L	QTY.	REMARKS	
PROJECT NAME:				
名称TITLE				
AGxx6 series				
Outline diagram				
図面番号DRAWING NO.				
9-772-004				
REV. MARK				
◇				

MARK	変更	REVISIONS	年月
			DATE

Headquarter Switzerland:
Pewatron AG
Thurgauerstrasse 66
CH-8050 Zurich
Phone +41 44 877 35 00
info@pewatron.com

Office Germany:
Pewatron Deutschland GmbH
Edisonstraße 16
D-85716 Unterschleißheim
Phone +49 89 374 288 87-0
info.de@pewatron.com



PEWATRON
SENSORS · POWER SOLUTIONS

We are here for you. Addresses and Contacts.

Sales Germany & Austria

Postcode 00000 – 31999
Postcode 38000 – 39999
Postcode 80000 – 99999
Austria

Kurt Stritzelberger

Phone +49 89 260 52 80
Mobile +49 171 803 41 35

kurt.stritzelberger@pewatron.com

Postcode 32000 – 37999
Postcode 40000 – 79999

Gerhard Vetter

Phone +49 674 394 75 75
Mobile +49 163 762 74 30

gerhard.vetter@pewatron.com

Geometrical sensors
Sensor elements

Thorsten Ravagni

Phone +49 60 479 53 627

thorsten.ravagni@pewatron.com

Sales Switzerland & Liechtenstein

Postcode 3000 – 9999

Basil Frei

Phone +41 44 877 35 18
Mobile +41 76 279 37 26

basil.frei@pewatron.com

Postcode 1000 – 2999

Christian Mohrenstecher

Mobile +41 76 444 57 93

christian.mohrenstecher@pewatron.com

Sales International Key Accounts

Peter Felder

Phone +41 44 877 35 05
Mobile +41 79 406 49 83

peter.felder@pewatron.com

Sales Other Countries / Product Management

Pressure Sensors

Philipp Kistler
Phone +41 44 877 35 03
philipp.kistler@pewatron.com

Accelerometers / Level Flow sensor elements

Thorsten Ravagni
Phone +49 60 479 53 627
thorsten.ravagni@pewatron.com

Drive technology CH Postcode 5000 – 9999 / DE

Roman Homa
Mobile +41 76 444 00 86
roman.homa@pewatron.com

Gas sensors / Gas sensor modules Load cells

Dr. Thomas Clausen
Phone +41 44 877 35 13
thomas.clausen@pewatron.com

Power supplies

Sebastiano Leggio
Phone +41 44 877 35 06
sebastiano.leggio@pewatron.com

Drive technology CH Postcode 1000 – 4999 / AT / IT / FR

Christian Mohrenstecher
Mobile +41 76 444 57 93
christian.mohrenstecher@pewatron.com

Flow / Level / Medical products

Dr. Adriano Pittarelli
Phone +49 8245 774 95 44
adriano.pittarelli@pewatron.com

Linear position sensors Angle sensors

Eric Letsch
Phone +41 44 877 35 14
eric.letsch@pewatron.com

Current sensors Power solutions

Osman Coban
Phone +49 71 635 363 898
osman.coban@pewatron.com